

Doboy CBS-D 750 Continuous Band Sealer.

7.50" OF HEAT SEALING SURFACE

QUALITY COMPONENTS FOR QUALITY SEALS

The CBS-D 750 comes standard with stainless steel construction of the mainframe and bridges. The wide-gap undercarriage plate, constructed from FDA-compliant coated aluminum, reduces head-space requirements allowing for smaller bag tops and material savings. The open frame design with polycarbonate guarding allows easy access and increased operating visibility for production and maintenance personnel. PTFE-coated fiberglass sealing bands provide superior seals and greatly reduce machine wear and maintenance.

SAFE & EASY OPERATION

All controls and adjustments are easy to use and set up. Floor stand is adjusted with a hand-crank for ideal operating height. Front guard doors are equipped with a safety interlock which stops the machine when the doors are opened and provides access to the sealing section. Sealing bands are easy to change without tools and can be done in less than two minutes!

AC DRIVE

The CBS-D 750 is a mid-range sealer that features the same drive system as our larger band sealers. This powerful and reliable combination features variable frequency speed control with a standard speed range up to 25m (1,000") per minute. Bag speed is precisely controlled from the operator panel. With the direct drive design, there is nothing to lubricate and no belts or chains to replace.

DIGITAL PRECISION TEMPERATURE CONTROL

The CBS-D 750's control system is a state-of-the-art digital temperature controller. Mounted in the operator panel, the controller provides precise control of the heat bar temperature. The heat bars reach set temperature in minutes and maintain the set point resulting in error-free seals.

BAG TOP CONTROL FOR QUALITY SEALS

Full length 12mm (1/2") urethane timing belts grip the bag top and provide positive timing and speed control as the bag top travels through the fully adjustable heat bars, compression wheels and cooling bars of the sealing section, resulting in strong, quality seals. Bags weighing less than three pounds don't require a support conveyor.

Sealing Section

- **Heat Bars** - One pair of 190mm (7.50") long precision machined aluminum heat bars produce a 6mm (1/4") wide seal. Ceramic insulators contain the heat and are spring-loaded to adjust for different bag thicknesses.
- **Compression Wheels** - One pair of adjustable spring-loaded compression wheels create the pressure needed to seal gusseted bags with ease.
- **Cooling Bars** - One pair of 5" long adjustable, cast aluminum, spring-loaded cooling bars with stainless steel cover and blower fan to set seals for immediate bag handling.



Packaging Line Structure.

Product Handling			Primary Packaging			Secondary Packaging		
Pick & Place	Distribution	Feeding	Flow Wrapping	Vertical Bagging	Bag Sealing	Forming	Closing	Loading

CBS-D 750

A wide variety of options

- ❑ Ink jet coders
- ❑ DRD Bag top trimmer
- ❑ Scrap removal
- ❑ Bag counter
- ❑ Band wiper
- ❑ Right to left or left to right feed directions
- ❑ Vertical and horizontal formats
- ❑ Custom options per application
- ❑ Tapered infeed extension
- ❑ Extended floor stand for increased elevation range
- ❑ 9mm (3/8"), 12mm (1/2"), 19mm (3/4") seal widths
- ❑ Optional voltages
- ❑ Integrated 2.5m (8') conveyor with 250mm (10") wide belt
- ❑ Integrated 3m (10') conveyor with 500mm (20") wide belt

Vertical Format

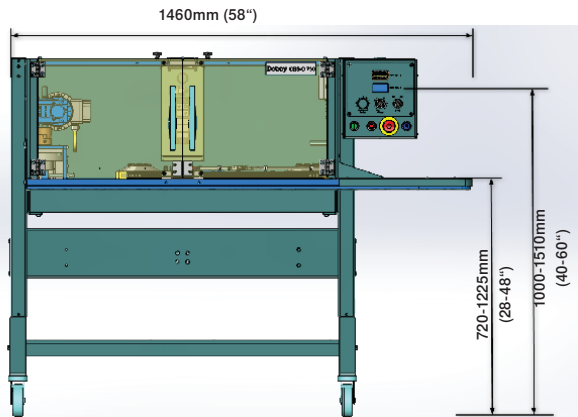

Horizontal Format

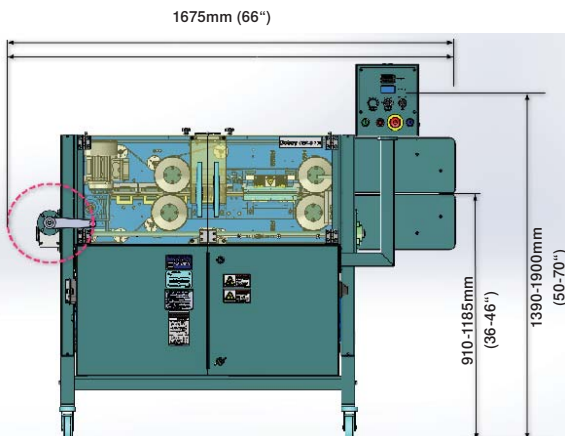

Technical Specifications

Machine Size	Vertical	Horizontal
Length	1460mm (58")	1675mm (66")
Width	890mm (35")	790mm (31")
Height	720 - 1225mm (28 - 48")	910 - 1185mm (36 - 46")
Weight	195kgs (430lbs)	95kgs (430lbs)
Specifications	min.	max.
Production Speed	Up to 25m (1,000") per minute	
Product Range	All heat-sealable materials, tube style or gusseted	
Sealing Bands	PTFE-coated fiberglass	
Sealing Width	6mm (0.25") standard	
Heat Bars	1 pair 190mm (7.50") long	
Compression	Adjustable pressure roller	
Cooling	1 pair of air-cooled bars	
Main Drive	AC drive / frequency control	
Temperature Control	One precision digital control	
Electrical	110 volt, 60 hz, 1 phase	

Syntegon Packaging Technology, LLC

869 South Knowles Avenue
New Richmond, WI 54017
USA

Phone +1 715 246 6511
Fax +1 715 246 6539
Mail sales.packaging-nrd@syntegon.com
Web www.syntegon.com

Subject CBS-D 750
Date 04.2020
Department PAUD/MKT